

DATA SHEET

74LVC16244A; 74LVCH16244A
16-bit buffer/line driver; 5 V
input/output tolerant; 3-state

Product specification
Supersedes data of 2003 Jan 30

2003 Dec 08

16-bit buffer/line driver; 5 V input/output tolerant; 3-state

74LVC16244A; 74LVCH16244A

FEATURES

- 5 V tolerant inputs/outputs for interfacing with 5 V logic
- Wide supply voltage range from 1.2 to 3.6 V
- CMOS low power consumption
- MULTIBYTE™ flow-through standard pin-out architecture
- Low inductance multiple power and ground pins for minimum noise and ground bounce
- Direct interface with TTL levels
- All data inputs have bushold (74LVCH16244A only).
- Complies with JEDEC standard no. 8-1A
- ESD protection:
HBM EIA/JESD22-A114-A exceeds 2000 V
MM EIA/JESD22-A115-A exceeds 200 V.
- Specified from –40 to +85 °C and –40 to +125 °C.

DESCRIPTION

The 74LVC(H)16244A is a high-performance, low power, low voltage, Si-gate CMOS device, superior to most advanced CMOS compatible TTL families. Inputs can be driven from either 3.3 or 5 V devices. In 3-state operation, outputs can handle 5 Volt. These features allow the use of these devices as a mixed 3.3 and 5 V environment.

The 74LVC(H)16244A is a 16-bit non-inverting buffer/line driver with 3-state outputs. The device can be used as four 4-bit buffers, two 8-bit buffers or one 16-bit buffer. The device features four Output Enables (1OE, 2OE, 3OE and 4OE), each controlling four of the 3-state outputs. A HIGH on nOE causes the outputs to assume a high-impedance OFF-state.

The 74LVC(H)16244A is identical to the 74LVC16240A but has non-inverting outputs.

The 74LVCH16244A bushold data inputs eliminates the need for external pull-up resistors to hold unused inputs.

QUICK REFERENCE DATA

GND = 0 V; T_{amb} = 25 °C; t_r = t_f ≤ 2.5 ns.

SYMBOL	PARAMETER	CONDITIONS	TYPICAL	UNIT
t _{PHL} /t _{PLH}	propagation delay nAn to nYn	C _L = 50 pF; V _{CC} = 3.3 V	3.0	ns
t _{PZH} /t _{PZL}	3-state output enable time nOE to nYn	C _L = 50 pF; V _{CC} = 3.3 V	3.5	ns
t _{PHZ} /t _{PLZ}	3-state output disable time nOE to nYn	C _L = 50 pF; V _{CC} = 3.3 V	3.7	ns
C _I	input capacitance		5.0	pF
C _{PD}	power dissipation capacitance per gate	V _{CC} = 3.3 V; notes 1 and 2		
		outputs enabled	12	pF
		outputs disabled	4.0	pF

Notes

1. C_{PD} is used to determine the dynamic power dissipation (P_D in μW).

$$P_D = C_{PD} \times V_{CC}^2 \times f_i \times N + \Sigma(C_L \times V_{CC}^2 \times f_o) \text{ where:}$$

f_i = input frequency in MHz;

f_o = output frequency in MHz;

C_L = output load capacitance in pF;

V_{CC} = supply voltage in Volts;

N = total load switching outputs;

Σ(C_L × V_{CC}² × f_o) = sum of the outputs.

2. The condition is V_i = GND to V_{CC}.

16-bit buffer/line driver; 5 V input/output
tolerant; 3-state

74LVC16244A;
74LVCH16244A

FUNCTION TABLE

See note 1.

INPUT		OUTPUT
$\overline{\text{nOE}}$	nAn	nYn
L	L	L
L	H	H
H	X	Z

Note

- H = HIGH voltage level;
L = LOW voltage level;
X = don't care;
Z = high-impedance OFF-state.

ORDERING INFORMATION

TYPE NUMBER	PACKAGE				
	TEMPERATURE RANGE	PINS	PACKAGE	MATERIAL	CODE
74LVC16244ADL	-40 to +125 °C	48	SSOP48	plastic	SOT370-1
74LVCH16244ADL	-40 to +125 °C	48	SSOP48	plastic	SOT370-1
74LVC16244ADGG	-40 to +125 °C	48	TSSOP48	plastic	SOT362-1
74LVCH16244ADGG	-40 to +125 °C	48	TSSOP48	plastic	SOT362-1
74LVC16244AEV	-40 to +125 °C	56	VFBGA56	plastic	SOT702-1
74LVCH16244AEV	-40 to +125 °C	56	VFBGA56	plastic	SOT702-1

16-bit buffer/line driver; 5 V input/output
tolerant; 3-state

74LVC16244A;
74LVCH16244A

PINNING

SYMBOL	PIN	BALL	DESCRIPTION
1 \overline{OE}	1	A1	output enable input (active LOW)
n.c.	–	A2, A3, A4, A5, K2, K3, K4, K5	not connected
1Y0	2	B2	data output
1Y1	3	B1	data output
GND	4, 10, 15, 21, 28, 34, 39, 45	B3, B4, D3, D4, G3, G4, J3, J4	ground (0 V)
1Y2	5	C2	data output
1Y3	6	C1	data output
V _{CC}	7, 18, 31, 42	C3, H3, C4, H4	supply voltage
2Y0	8	D2	data output
2Y1	9	D1	data output
2Y2	11	E2	data output
2Y3	12	E1	data output
3Y0	13	F1	data output
3Y1	14	F2	data output
3Y2	16	G1	data output
3Y3	17	G2	data output
4Y0	19	H1	data output
4Y1	20	H2	data output
4Y2	22	J1	data output
4Y3	23	J2	data output
4 \overline{OE}	24	K1	output enable input (active LOW)
3 \overline{OE}	25	K6	output enable input (active LOW)
4A3	26	J5	data input
4A2	27	J6	data input
4A1	29	H5	data input
4A0	30	H6	data input
3A3	32	G5	data input
3A2	33	G6	data input
3A1	35	F5	data input
3A0	36	F6	data input
2A3	37	E6	data input
2A2	38	E5	data input
2A1	40	D6	data input
2A0	41	D5	data input
1A3	43	C6	data input
1A2	44	C5	data input
1A1	46	B6	data input
1A0	47	B5	data input
2 \overline{OE}	48	A6	output enable input (active LOW)

16-bit buffer/line driver; 5 V input/output tolerant; 3-state

74LVC16244A;
74LVCH16244A

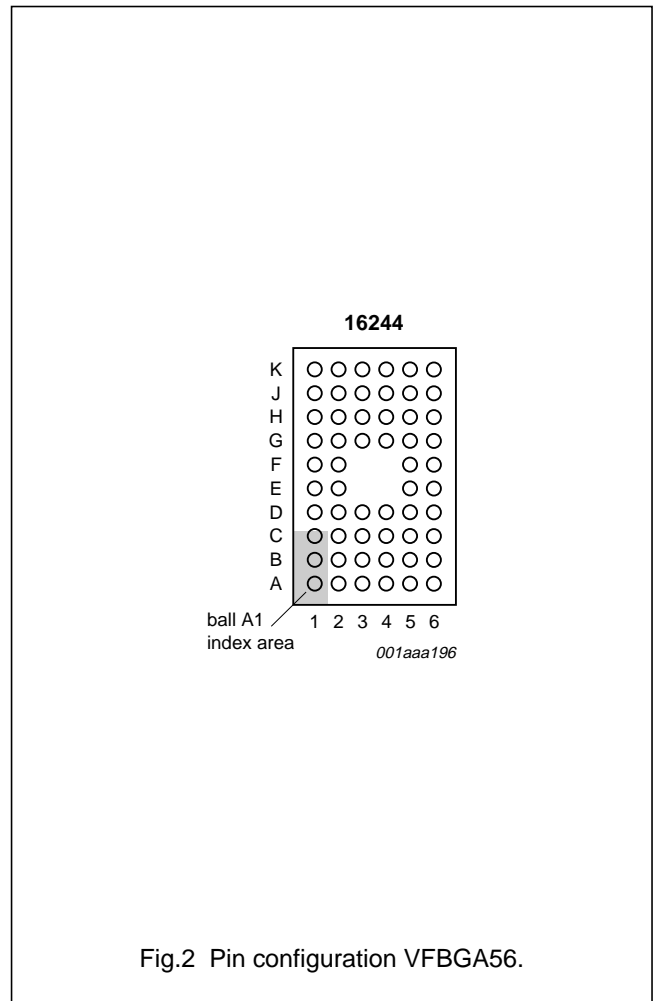
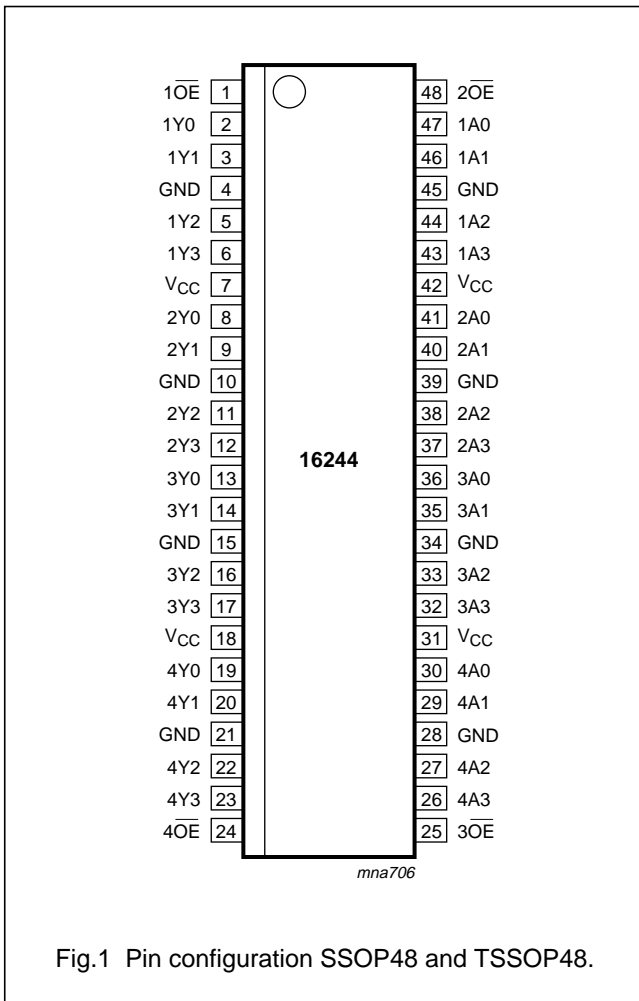

16-bit buffer/line driver; 5 V input/output tolerant; 3-state

74LVC16244A;
74LVCH16244A

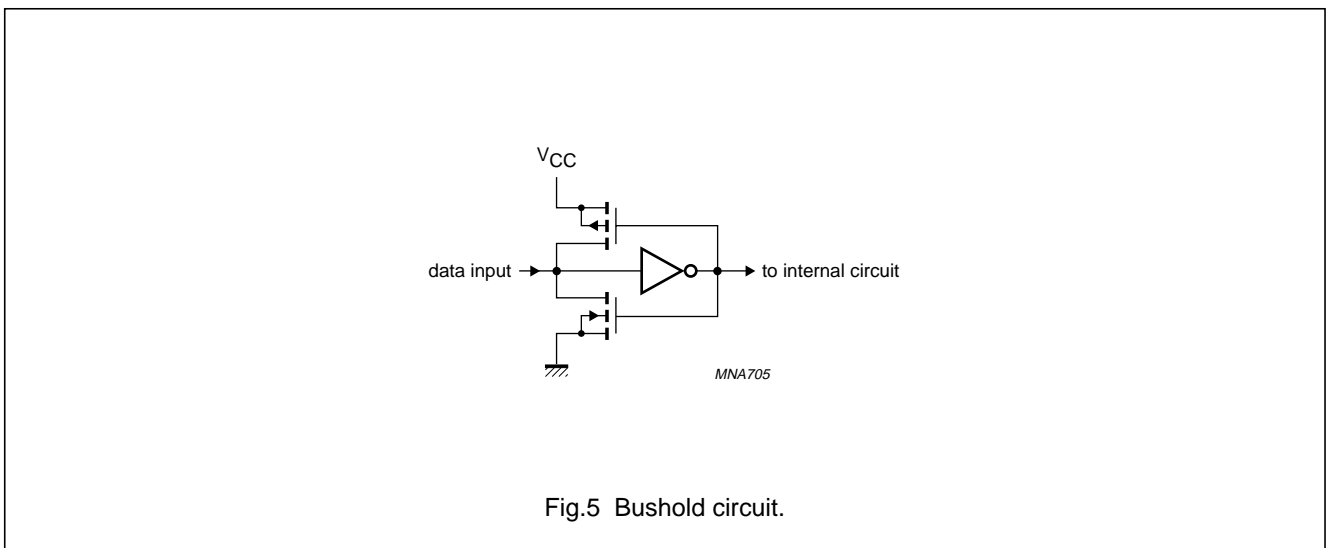
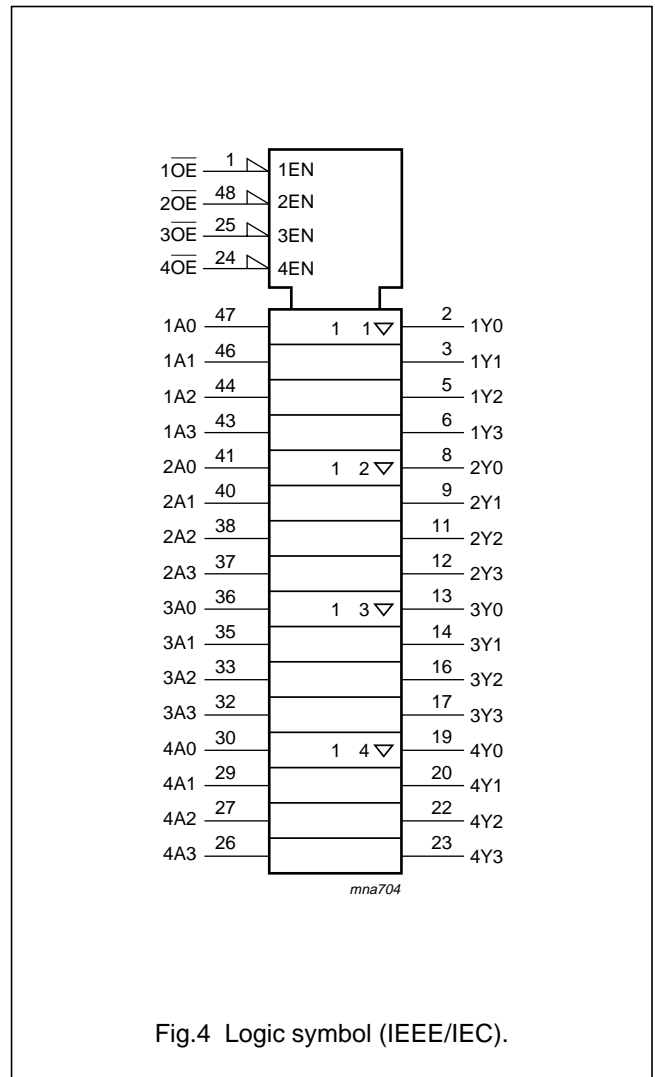
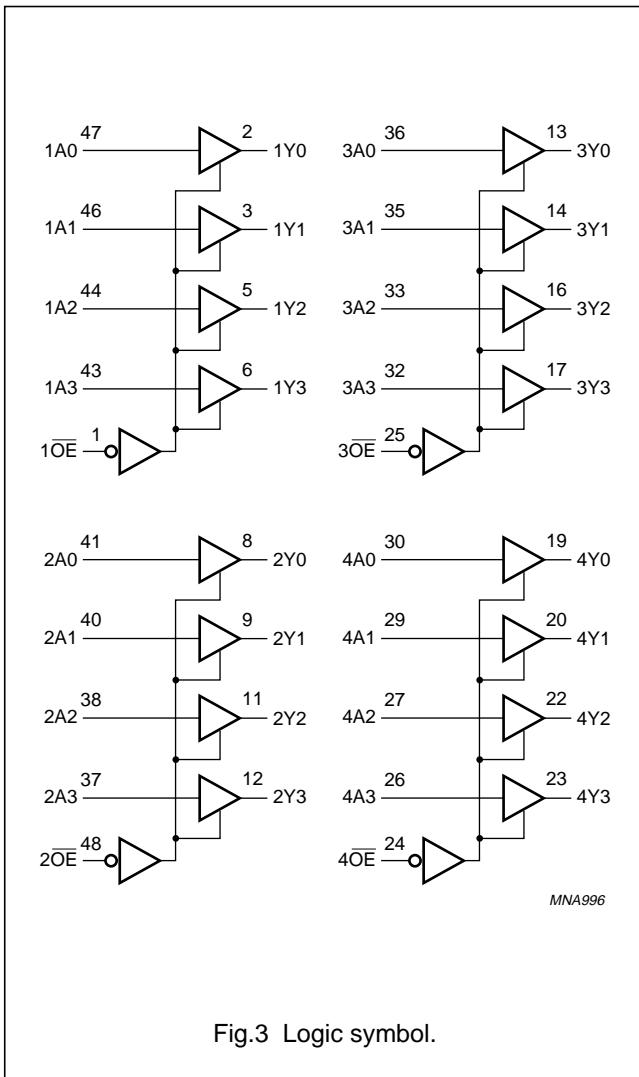

16-bit buffer/line driver; 5 V input/output
tolerant; 3-state

74LVC16244A;
74LVCH16244A

RECOMMENDED OPERATING CONDITIONS

SYMBOL	PARAMETER	CONDITIONS	MIN.	MAX.	UNIT
V _{CC}	supply voltage	for maximum speed performance	2.7	3.6	V
		for low voltage applications	1.2	3.6	V
V _I	input voltage		0	5.5	V
V _O	output voltage	output HIGH or LOW state	0	V _{CC}	V
		output 3-state	0	5.5	V
T _{amb}	operating ambient temperature	in free air	-40	+125	°C
t _r , t _f	input rise and fall times	V _{CC} = 1.2 to 2.7 V	0	20	ns/V
		V _{CC} = 2.7 to 3.6 V	0	10	ns/V

LIMITING VALUES

In accordance with the Absolute Maximum Rating System (IEC 60134); voltages are referenced to GND (ground = 0 V).

SYMBOL	PARAMETER	CONDITIONS	MIN.	MAX.	UNIT
V _{CC}	supply voltage		-0.5	+6.5	V
I _{IK}	input diode current	V _I < 0	-	-50	mA
V _I	input voltage	note 1	-0.5	+6.5	V
I _{OK}	output diode current	V _O > V _{CC} or V _O < 0	-	±50	mA
V _O	output voltage	output HIGH or LOW state; note 1	-0.5	V _{CC} + 0.5	V
		output 3-state; note 1	-0.5	+6.5	V
I _O	output source or sink current	V _O = 0 to V _{CC}	-	±50	mA
I _{CC} , I _{GND}	V _{CC} or GND current		-	±100	mA
T _{stg}	storage temperature		-65	+150	°C
P _{tot}	power dissipation SSOP and TSSOP package VFPGA package	T _{amb} = -40 to +125 °C; note 2	-	500	mW
		T _{amb} = -40 to +125 °C; note 3	-	1000	mW

Notes

- The input and output voltage ratings may be exceeded if the input and output current ratings are observed.
- Above 60 °C the value of P_{tot} derates linearly with 5.5 mW/K.
- Above 70 °C the value of P_{tot} derates linearly with 1.8 mW/K.

**16-bit buffer/line driver; 5 V input/output
tolerant; 3-state**
**74LVC16244A;
74LVCH16244A**
DC CHARACTERISTICS

At recommended operating conditions; voltages are referenced to GND (ground = 0 V).

SYMBOL	PARAMETER	TEST CONDITIONS		MIN.	TYP.	MAX.	UNIT
		OTHER	V _{CC} (V)				
T_{amb} = -40 to +85 °C; note 1							
V _{IH}	HIGH-level input voltage		1.2	V _{CC}	-	-	V
			2.7 to 3.6	2.0	-	-	V
V _{IL}	LOW-level input voltage		1.2	-	-	0	V
			2.7 to 3.6	-	-	0.8	V
V _{OH}	HIGH-level output voltage	V _I = V _{IH} or V _{IL}	2.7 to 3.6	V _{CC} - 0.2	V _{CC}	-	V
		I _O = -100 µA	2.7	V _{CC} - 0.5	-	-	V
		I _O = -12 mA	3.0	V _{CC} - 0.6	-	-	V
		I _O = -24 mA	3.0	V _{CC} - 0.8	-	-	V
V _{OL}	LOW-level output voltage	V _I = V _{IH} or V _{IL}	2.7 to 3.6	-	0	0.20	V
		I _O = 100 µA	2.7	-	-	0.40	V
		I _O = 24 mA	3.0	-	-	0.55	V
I _{LI}	input leakage current	V _I = 5.5 V or GND; note 2	3.6	-	±0.1	±5	µA
I _{OZ}	3-state output OFF-state current	V _I = V _{IH} or V _{IL} ; V _O = 5.5 V or GND; note 2	3.6	-	0.1	±5	µA
I _{off}	power-off leakage supply current	V _I or V _O = 5.5 V	0.0	-	0.1	±10	µA
I _{CC}	quiescent supply current	V _I = V _{CC} or GND; I _O = 0	3.6	-	0.1	20	µA
ΔI _{CC}	additional quiescent supply current per input pin	V _I = V _{CC} - 0.6 V; I _O = 0	2.7 to 3.6	-	5	500	µA
I _{BH}	bushold LOW sustaining current	V _I = 0.8 V; notes 3 and 4	3.0	75	-	-	µA
I _{BHH}	bushold HIGH sustaining current	V _I = 2.0 V; notes 3 and 4	3.0	-75	-	-	µA
I _{BHLO}	bushold LOW overdrive current	notes 3 and 5	3.6	500	-	-	µA
I _{BHHO}	bushold HIGH overdrive current	notes 3 and 5	3.6	-500	-	-	µA

16-bit buffer/line driver; 5 V input/output tolerant; 3-state

74LVC16244A;
74LVCH16244A

SYMBOL	PARAMETER	TEST CONDITIONS		MIN.	TYP.	MAX.	UNIT
		OTHER	V _{CC} (V)				
T_{amb} = -40 to +125 °C							
V _{IH}	HIGH-level input voltage		1.2	V _{CC}	-	-	V
			2.7 to 3.6	2.0	-	-	V
V _{IL}	LOW-level input voltage		1.2	-	-	0	V
			2.7 to 3.6	-	-	0.8	V
V _{OH}	HIGH-level output voltage	V _I = V _{IH} or V _{IL}	2.7 to 3.6	V _{CC} - 0.3	-	-	V
		I _O = -100 μA	2.7	V _{CC} - 0.65	-	-	V
		I _O = -12 mA	3.0	V _{CC} - 0.75	-	-	V
		I _O = -18 mA	3.0	V _{CC} - 1	-	-	V
V _{OL}	LOW-level output voltage	V _I = V _{IH} or V _{IL}	2.7 to 3.6	-	-	0.3	V
		I _O = 100 μA	2.7	-	-	0.6	V
		I _O = 12 mA	3.0	-	-	0.8	V
		I _O = 24 mA	3.0	-	-	0.8	V
I _{LI}	input leakage current	V _I = 5.5 V or GND; note 2	3.6	-	-	±20	μA
I _{OZ}	3-state output OFF-state current	V _I = V _{IH} or V _{IL} ; V _O = 5.5 V or GND; note 2	3.6	-	-	±20	μA
I _{off}	power-off leakage supply current	V _I or V _O = 5.5 V	0.0	-	-	±20	μA
I _{CC}	quiescent supply current	V _I = V _{CC} or GND; I _O = 0	3.6	-	-	80	μA
ΔI _{CC}	additional quiescent supply current per input pin	V _I = V _{CC} - 0.6 V; I _O = 0	2.7 to 3.6	-	-	5000	μA
I _{BH}	bushold LOW sustaining current	V _I = 0.8 V; notes 3 and 4	3.0	60	-	-	μA
I _{BHH}	bushold HIGH sustaining current	V _I = 2.0 V; notes 3 and 4	3.0	-60	-	-	μA
I _{BHLO}	bushold LOW overdrive current	notes 3 and 5	3.6	500	-	-	μA
I _{BHHO}	bushold HIGH overdrive current	notes 3 and 5	3.6	-500	-	-	μA

Notes

1. All typical values are measured at V_{CC} = 3.3 V and T_{amb} = 25 °C.
2. For bushold parts, the bushold circuit is switched off when V_I > V_{CC} allowing 5.5 V on the input pin.
3. Valid for data inputs of bushold parts (74LVCH16244A) only. For data inputs only, control inputs do not have a bushold circuit.
4. The specified sustaining current at the data inputs holds the input below the specified V_I level.
5. The specified overdrive current at the data input forces the data input to the opposite logic input state.

16-bit buffer/line driver; 5 V input/output
tolerant; 3-state

74LVC16244A;
74LVCH16244A

AC CHARACTERISTICS

GND = 0 V; $t_r = t_f \leq 2.5$ ns; $C_L = 50$ pF; $R_L = 500$ Ω .

SYMBOL	PARAMETER	CONDITIONS		MIN.	TYP.	MAX.	UNIT
		WAVEFORMS	V _{CC} (V)				
T_{amb} = -40 to +85 °C; note1							
t _{PHL} /t _{PLH}	propagation delay nAn to nYn	see Figs 6 and 8	1.2	–	11.0	–	ns
			2.7	1.0	–	4.7	ns
			3.0 to 3.6	1.1	3.0 ⁽²⁾	4.1	ns
t _{PZH} /t _{PZL}	3-state output enable time n \overline{OE} to nYn	see Figs 7 and 8	1.2	–	15.0	–	ns
			2.7	1.0	–	5.8	ns
			3.0 to 3.6	1.0	3.5 ⁽²⁾	4.6	ns
t _{PHZ} /t _{PLZ}	3-state output disable time n \overline{OE} to nYn	see Figs 7 and 8	1.2	–	10.0	–	ns
			2.7	1.0	–	6.2	ns
			3.0 to 3.6	1.8	3.7 ⁽²⁾	5.2	ns
T_{amb} = -40 to +125 °C							
t _{PHL} /t _{PLH}	propagation delay nAn to nYn	see Figs 6 and 8	1.2	–	–	–	ns
			2.7	1.0	–	6.0	ns
			3.0 to 3.6	1.1	–	5.5	ns
t _{PZH} /t _{PZL}	3-state output enable time n \overline{OE} to nYn	see Figs 7 and 8	1.2	–	–	–	ns
			2.7	1.0	–	7.5	ns
			3.0 to 3.6	1.0	–	6.0	ns
t _{PHZ} /t _{PLZ}	3-state output disable time n \overline{OE} to nYn	see Figs 7 and 8	1.2	–	–	–	ns
			2.7	1.0	–	8.0	ns
			3.0 to 3.6	1.8	–	6.5	ns

Notes

1. All typical values are measured at T_{amb} = 25 °C.
2. These typical values are measured at V_{CC} = 3.3 V and T_{amb} = 25 °C.

16-bit buffer/line driver; 5 V input/output tolerant; 3-state

74LVC16244A;
74LVCH16244A

AC WAVEFORMS

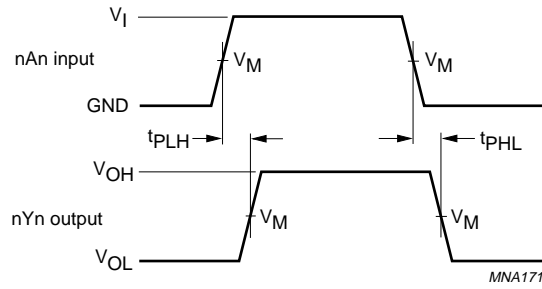

V _{CC}	V _M	INPUT	
		V _I	t _r = t _f
1.2 V	0.5 × V _{CC}	V _{CC}	≤ 2.5 ns
2.7 V	1.5 V	2.7 V	≤ 2.5 ns
3.0 to 3.6 V	1.5 V	2.7 V	≤ 2.5 ns

V_{OL} and V_{OH} are typical output voltage drop that occur with the output load.

Fig.6 The input nAn to output nYn propagation delays.

16-bit buffer/line driver; 5 V input/output tolerant; 3-state

74LVC16244A;
74LVCH16244A

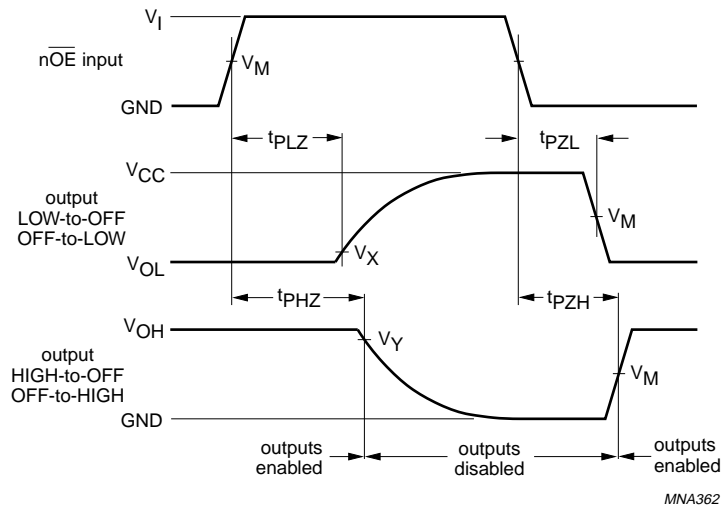

V _{CC}	V _M	INPUT	
		V _I	t _r = t _f
1.2 V	0.5 × V _{CC}	V _{CC}	≤ 2.5 ns
2.7 V	1.5 V	2.7 V	≤ 2.5 ns
3.0 to 3.6 V	1.5 V	2.7 V	≤ 2.5 ns

V_X = V_{OL} + 0.3 V at V_{CC} ≥ 2.7 V;
 V_X = V_{OL} + 0.1 V at V_{CC} < 2.7 V;
 V_Y = V_{OH} - 0.3 V at V_{CC} ≥ 2.7 V;
 V_Y = V_{OH} - 0.1 V at V_{CC} < 2.7 V.

V_{OL} and V_{OH} are typical output voltage drop that occur with the output load.

Fig.7 3-state enable and disable times.

16-bit buffer/line driver; 5 V input/output tolerant; 3-state

74LVC16244A;
74LVCH16244A

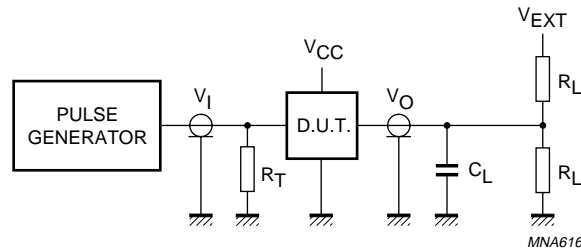

V _{CC}	V _I	C _L	R _L	V _{EXT}		
				t _{PLH} /t _{PHL}	t _{PZH} /t _{PHZ}	t _{PZL} /t _{PLZ}
1.2 V	V _{CC}	50 pF	500 Ω ⁽¹⁾	open	GND	2 × V _{CC}
2.7 V	2.7 V	50 pF	500 Ω	open	GND	2 × V _{CC}
3.0 to 3.6 V	2.7 V	50 pF	500 Ω	open	GND	2 × V _{CC}

Note

1. The circuit performs better when R_L = 1000 Ω.

Definitions for test circuits:

R_L = Load resistor.

C_L = Load capacitance including jig and probe capacitance.

R_T = Termination resistance should be equal to the output impedance Z_o of the pulse generator.

Fig.8 Load circuitry for switching times.

16-bit buffer/line driver; 5 V input/output tolerant; 3-state

74LVC16244A;
74LVCH16244A

PACKAGE OUTLINES

SSOP48: plastic shrink small outline package; 48 leads; body width 7.5 mm

SOT370-1

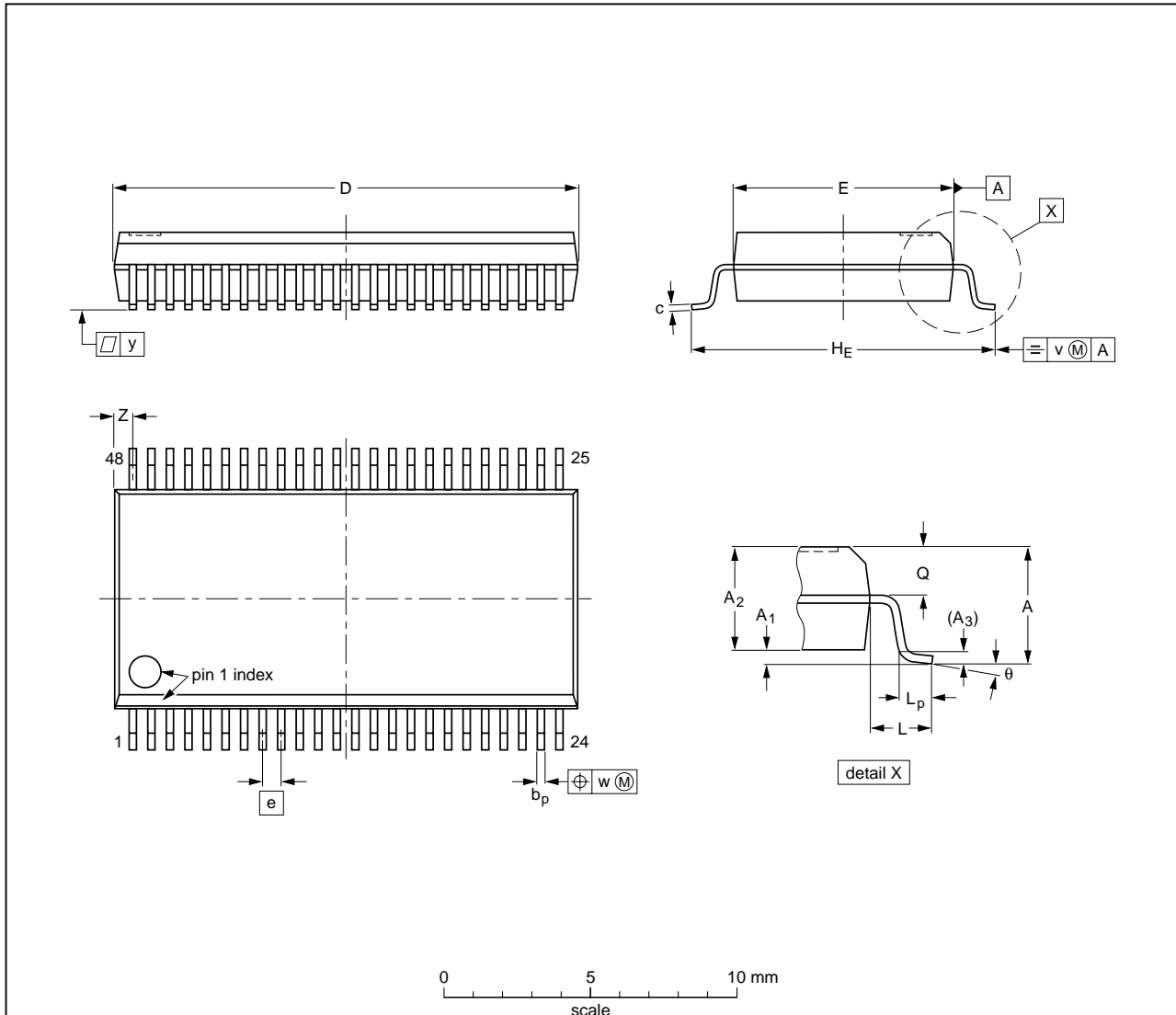

DIMENSIONS (mm are the original dimensions)

UNIT	A max.	A ₁	A ₂	A ₃	b _p	c	D ⁽¹⁾	E ⁽¹⁾	e	H _E	L	L _p	Q	v	w	y	z ⁽¹⁾	θ
mm	2.8	0.4 0.2	2.35 2.20	0.25	0.3 0.2	0.22 0.13	16.00 15.75	7.6 7.4	0.635	10.4 10.1	1.4	1.0 0.6	1.2 1.0	0.25	0.18	0.1	0.85 0.40	8° 0°

Note
1. Plastic or metal protrusions of 0.25 mm maximum per side are not included.

OUTLINE VERSION	REFERENCES			EUROPEAN PROJECTION	ISSUE DATE
	IEC	JEDEC	JEITA		
SOT370-1		MO-118			99-12-27 03-02-19

16-bit buffer/line driver; 5 V input/output tolerant; 3-state

74LVC16244A;
74LVCH16244A

TSSOP48: plastic thin shrink small outline package; 48 leads; body width 6.1 mm

SOT362-1

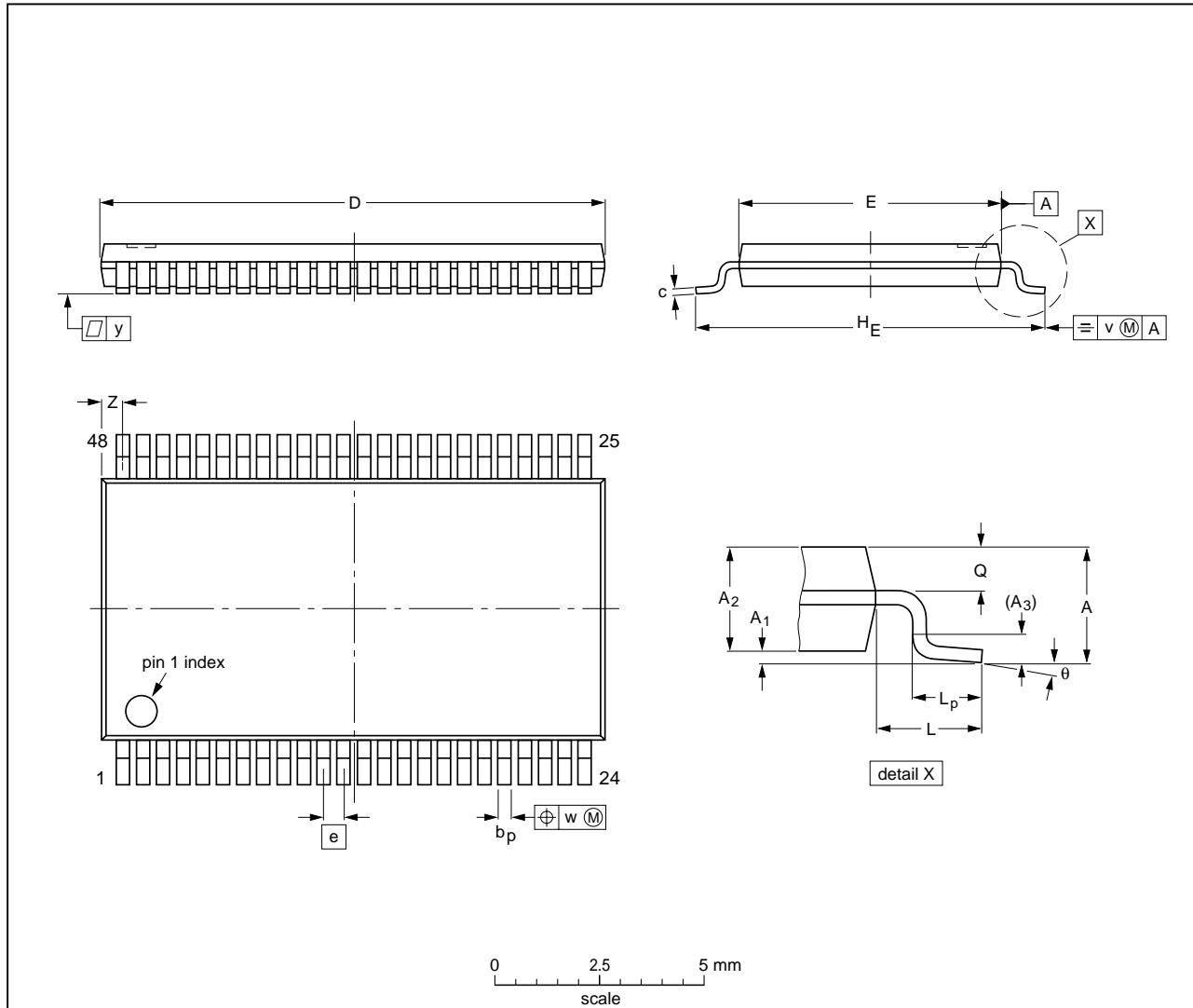

DIMENSIONS (mm are the original dimensions).

UNIT	A max.	A ₁	A ₂	A ₃	b _p	c	D ⁽¹⁾	E ⁽²⁾	e	H _E	L	L _p	Q	v	w	y	Z	θ
mm	1.2	0.15 0.05	1.05 0.85	0.25	0.28 0.17	0.2 0.1	12.6 12.4	6.2 6.0	0.5	8.3 7.9	1	0.8 0.4	0.50 0.35	0.25	0.08	0.1	0.8 0.4	8° 0°

Notes

1. Plastic or metal protrusions of 0.15 mm maximum per side are not included.
2. Plastic interlead protrusions of 0.25 mm maximum per side are not included.

OUTLINE VERSION	REFERENCES			EUROPEAN PROJECTION	ISSUE DATE
	IEC	JEDEC	JEITA		
SOT362-1		MO-153			99-12-27 03-02-19

16-bit buffer/line driver; 5 V input/output tolerant; 3-state

74LVC16244A;
74LVCH16244A

VFBGA56: plastic very thin fine-pitch ball grid array package; 56 balls; body 4.5 x 7 x 0.65 mm

SOT702-1

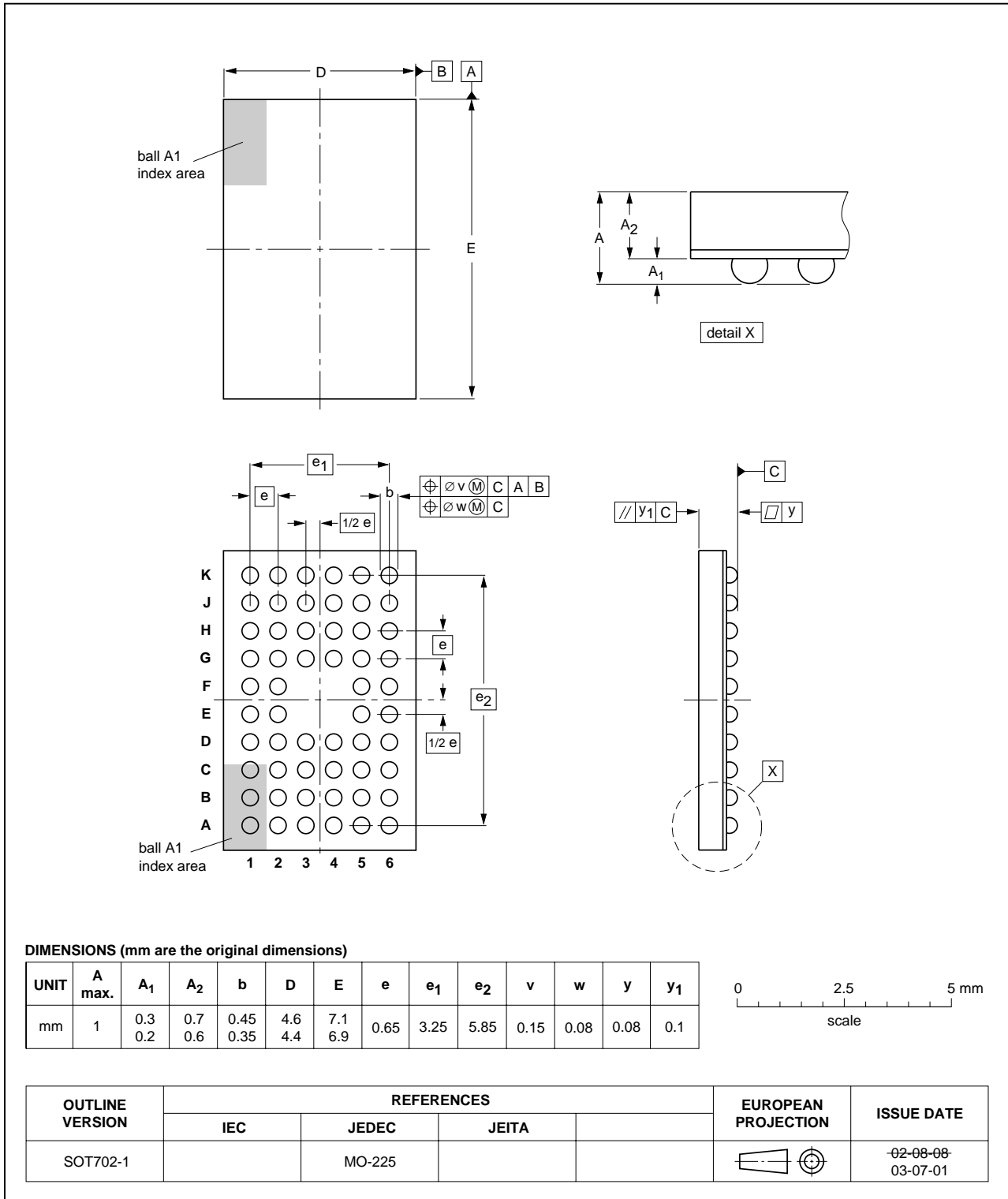

16-bit buffer/line driver; 5 V input/output
tolerant; 3-state

74LVC16244A;
74LVCH16244A

DATA SHEET STATUS

LEVEL	DATA SHEET STATUS ⁽¹⁾	PRODUCT STATUS ⁽²⁾⁽³⁾	DEFINITION
I	Objective data	Development	This data sheet contains data from the objective specification for product development. Philips Semiconductors reserves the right to change the specification in any manner without notice.
II	Preliminary data	Qualification	This data sheet contains data from the preliminary specification. Supplementary data will be published at a later date. Philips Semiconductors reserves the right to change the specification without notice, in order to improve the design and supply the best possible product.
III	Product data	Production	This data sheet contains data from the product specification. Philips Semiconductors reserves the right to make changes at any time in order to improve the design, manufacturing and supply. Relevant changes will be communicated via a Customer Product/Process Change Notification (CPCN).

Notes

1. Please consult the most recently issued data sheet before initiating or completing a design.
2. The product status of the device(s) described in this data sheet may have changed since this data sheet was published. The latest information is available on the Internet at URL <http://www.semiconductors.philips.com>.
3. For data sheets describing multiple type numbers, the highest-level product status determines the data sheet status.

DEFINITIONS

Short-form specification — The data in a short-form specification is extracted from a full data sheet with the same type number and title. For detailed information see the relevant data sheet or data handbook.

Limiting values definition — Limiting values given are in accordance with the Absolute Maximum Rating System (IEC 60134). Stress above one or more of the limiting values may cause permanent damage to the device. These are stress ratings only and operation of the device at these or at any other conditions above those given in the Characteristics sections of the specification is not implied. Exposure to limiting values for extended periods may affect device reliability.

Application information — Applications that are described herein for any of these products are for illustrative purposes only. Philips Semiconductors make no representation or warranty that such applications will be suitable for the specified use without further testing or modification.

DISCLAIMERS

Life support applications — These products are not designed for use in life support appliances, devices, or systems where malfunction of these products can reasonably be expected to result in personal injury. Philips Semiconductors customers using or selling these products for use in such applications do so at their own risk and agree to fully indemnify Philips Semiconductors for any damages resulting from such application.

Right to make changes — Philips Semiconductors reserves the right to make changes in the products - including circuits, standard cells, and/or software - described or contained herein in order to improve design and/or performance. When the product is in full production (status 'Production'), relevant changes will be communicated via a Customer Product/Process Change Notification (CPCN). Philips Semiconductors assumes no responsibility or liability for the use of any of these products, conveys no licence or title under any patent, copyright, or mask work right to these products, and makes no representations or warranties that these products are free from patent, copyright, or mask work right infringement, unless otherwise specified.

Philips Semiconductors – a worldwide company

Contact information

For additional information please visit <http://www.semiconductors.philips.com>. Fax: +31 40 27 24825

For sales offices addresses send e-mail to: sales.addresses@www.semiconductors.philips.com.

© Koninklijke Philips Electronics N.V. 2003

SCA75

All rights are reserved. Reproduction in whole or in part is prohibited without the prior written consent of the copyright owner.

The information presented in this document does not form part of any quotation or contract, is believed to be accurate and reliable and may be changed without notice. No liability will be accepted by the publisher for any consequence of its use. Publication thereof does not convey nor imply any license under patent- or other industrial or intellectual property rights.

Printed in The Netherlands

R20/07/pp18

Date of release: 2003 Dec 08

Document order number: 9397 750 12369

Let's make things better.

**Philips
Semiconductors**



PHILIPS